

Instructions

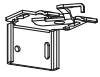

L<1m 2pcs
 1m<L≤1.5m 3pcs
 1.5m<L≤2m 4pcs
 L>2m 5pcs



1pcs



1pcs



L<1m 5pcs
 1m<L≤1.5m 7pcs
 1.5m<L≤2m 9pcs
 L>2m 11pcs

Option

A. Top

B. Wall

C. Ceiling

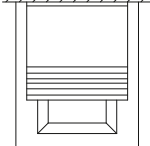
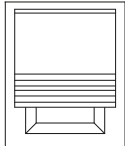
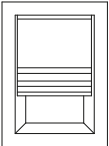

1A/C

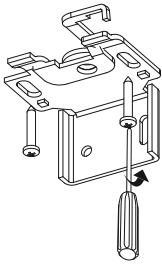

1B

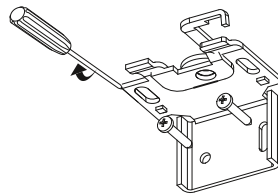

2

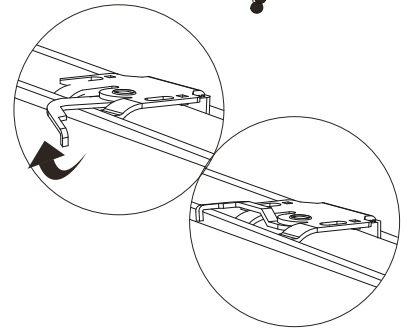
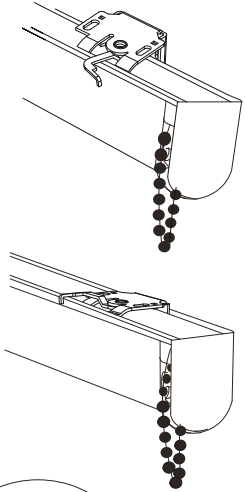

3

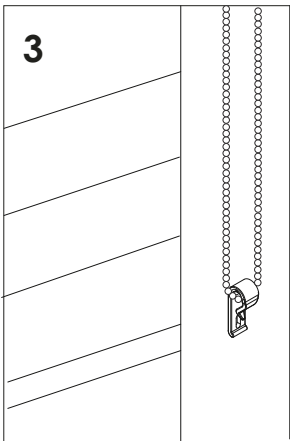

∅ 3mm

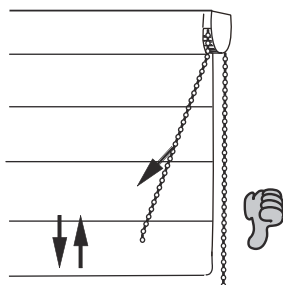
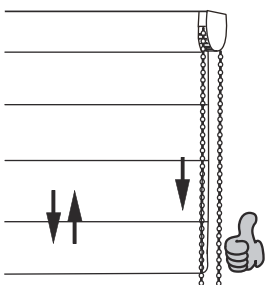
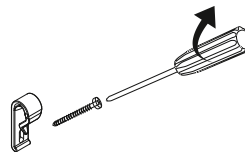
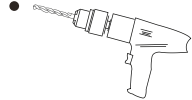

**SÄKERHETSINSTRUKTION****CHILD SAFETY INSTRUCTION****SICHERHEITSINSTRUKTION****TURVALLISUUSOHJEET**

Läs instruktionen noggrant före användning

The instruction for use shall be read before operating of the product

Lesen Sie die Instruktion sorgfältig bevor Gebrauch

Lue ohjeet huolellisesti ennen käyttöä

! WARNING

Det har hänt att småbarn har stryps i snaror som uppstått på linor, kedjor och band samt manövringslinor. Se till att linor/kedjor är utom räckhåll för barn, för att undervika stryp eller insnärjningsolyckor. Linor/kedjor kan sno sig runt halsen på ett barn. Knyt inte ihop linor. Se till så att linorna inte tvinnas ihop eller bildar en snara. För att minska risken montera medföljande säkerhetsutrustning enligt instruktion nedan:

Fäst den nedhängande delen av dragsnöret eller kedjan utom räckhåll för barn, genom att linda upp hela dragsnöret runt knapen.



Knappe till persienner, rolluper, hiss- och plisségardiner.

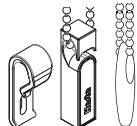

Fästningsordningar för kedja/lina till roll- och lamellgardiner.

Kedjor till rullgardiner bör fästas permanent och spänt mot väggen med hjälp av medföljande fäst-anordning.

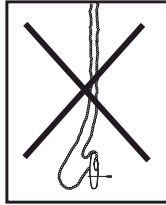
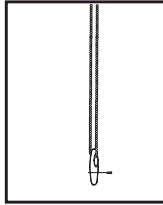

Låt inte barn leka med linor/kedjor. Flytta bort sängar och andra möbler från linor till solskydd och andra gardiner.



Lösa smådelar kan förorsaka kvävning hos barn. Byt ut anordningen om den är trasig.

Läs monteringsinstruktionen noggrant.

! WARNING

Es ist passiert dass kleine Kinder sich erwürgt haben durch Schlaufen bei Schnüren, Leinen und Ketten. Sehe zu dass Leinen/Ketten ausser Reichweite von Kindern sind, um Er-würgungsunglücke zu vermeiden. Leinen/Ketten können sich um den Hals der Kinder wickeln. Binde nicht die Leinen zusammen. Sehe zu dass die Leinen nicht eine Schlaufe bilden. Um dass Risiko zu vermeiden Montieren Sie die beigefügte Sicherheitsausrüstung neben an:

Befestigen Sie die runterhängende Schnur oder Kette ausser der Reichweite von Kindern, durch das Umwickeln des Knopfes.



Befestigung für Jalousien, Roll-ups, Faltstors und Plissés.



Befestigung für Rollos Kette/Leine für Rollos und Vertikalvorhänge.

Ketten von Rollos sollen permanent an der Wand gespannt sein mit der beigefügten Befestigung.

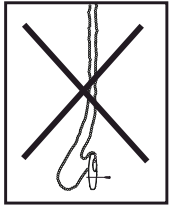
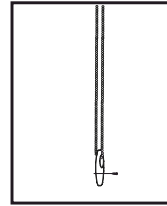

Lass die Kinder nicht mit Leinen/Ketten spielen. Stellen Sie Betten und andere Möbel bei seite, nicht in der Nähe von Sonnenschutzanlagen.



Lose Kleinteile können erstickung bei Kindern verursachen. Tauschen Sie bitte die Ausrüstung aus, wenn sie beschädigt ist!

Bitte lesen Sie die Montageanleitung sorgfältig!

! WARNING

Accidents have occurred when young children have been strangled in snares incurred of cords, chains, bands and strings. Cords/chains can contort around the neck of a child. To avoid strangulation or entangle accidents, make sure the cords/chains are out of reach for children. Do not tie cords. Assure the cords are not twisted or form a snare. To reduce the risk, you shall assemble the belonging child safety device according to instruction below:

Keep the hanging part of cord out of reach for children. Fixate the cord by wrap up the entire cord around the cleat.



Cordholder for rollerblinds, roll-ups, roman blinds and pleated blinds.

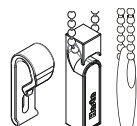

Chain/cord holders for rollerblind and vertical blinds.

Ball chains for roller blinds shall permanently be fixated and stretched (no slack) against the wall by using the belonging child safety device.

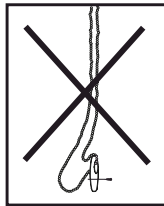
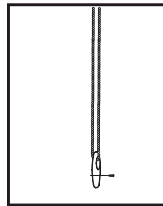

Do not allow children to play with cords/chains. Move away beds and other furniture from window products that have cords/chains.



Small parts can cause choking. Regularly check the safety device. Exchange the device if it is broken or do not work.

Read the assembling instruction carefully before you assemble and use the product.

! VAROITUS

On tapahtunut että pikku lapset on kuristuneet naruihin, ketjuihin ja nauhoihin tulleista silmukoista. Välttääkseen kuristus ja taker-tumisonnitemuudet, varmistaakaa että narut ja ketjut on poissa lasten ulottuvilta. Narut/ketjut voivat kietoutua lasten kaulan ympärille. Älkää solmikko naruja. Varmistakaa että narut ei kierry yhteen ja muodostavat silmukan. Riskin vähentämiseksi asentakaa mukana olevat turvaosat ohjeiden mukaan.

Punotkaa ylimääräiset roikkuvat narut ja lenkit useita kertoja knaapiin (turvaosan) ympärille, näin saadaan ylimääräiset narut pois lasten ulottuvilta.



Knaapi kaihtimille, rollup-, laskos- ja plissöverhoille

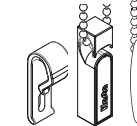

Kiinnike rulla- ja lamelliverhon ketjuille/naruille.

Rullaverhojen roikkuvat ketjut pitää kiristää tiukaksi seinään, mukana olevalla ketjukiristinkiinnikkeellä (turvaosa).

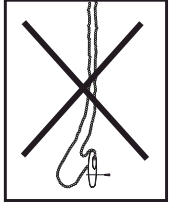
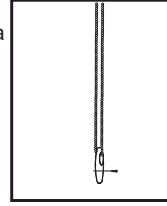

Älkää antako lasten leikkiä naruilla/ketjuilla. Siirtäkää pois sängyt ja muut huonekalut aurinkosuojien ja muitten verhojen narulita.



Irralliset pienet osat voivat aiheuttaa tukehtumisvaaran lapsille. Vaihatakaa turvosa, jos se on rikki.

Lukekaa asennusohjeet huolellisesti.